

SPECIFICATION OF PRECISION OSCILLATORS

Stanley S. Schodowski and John R. Vig
U.S. Army Electronics Technology and Devices Laboratory, LABCOM
Fort Monmouth, New Jersey 07703-5000

ABSTRACT

This paper reviews Revision B of the military specification for quartz crystal oscillators, MIL-0-55310B. The emphasis is on those aspects of MIL-0-55310B which are of greatest interest to the PTTI community, i.e., on specifying high precision oscillators. MIL-0-55310B has been "in the making" since 1982. The five-year effort, which included repeated government-industry coordinations, has produced a completely overhauled document that is expected to be released early in 1988. The revised specification will supercede MIL-0-55310A, which was issued on 29 November 1976. The B-revision now permits the specification (and acquisition) of the more reliable and higher performance crystal oscillators required by modern military and space systems.

Major modifications and improvements were made to the requirements specifying design and construction, performance and test, quality assurance, and qualification. Definitions were expanded and two new oscillator types, the microcomputer-compensated-crystal oscillator (MCXO) and the rubidium-crystal oscillator (RbXO), were added. An index has also been added to facilitate use of the specification.

Revision B contains more than thirty new performance (and corresponding test) requirements. Many existing requirements have been revised. Aspects of the new and revised requirements that are most relevant to PTTI are discussed in this paper. A future revision that would include all precision frequency sources, i.e., both crystal and atomic sources, is proposed.

INTRODUCTION

MIL-0-55310, the general specification for crystal oscillators, covers the technical requirements and test procedures for bulkwave quartz crystal oscillators designed for frequency control and timekeeping in military and space systems. This standardization document, in conjunction with associated specification sheets, supports the acquisition of crystal oscillators by all government agencies and their contractors. Since its introduction in 1970, MIL-0-55310 has primarily served to specify low precision crystal oscillators, e.g., the 25 ppm to 100 ppm clock oscillators and 5 ppm to 10 ppm TCXO's. As systems grew more sophisticated, it became increasingly apparent that MIL-0-55310A was inadequate for the specification of the required higher-performance crystal oscillators. A five year effort undertaken in 1982, and which included repeated government-industry coordinations, has resulted in the B revision, i.e., MIL-0-55310B.

Changes have been made in each major category of the specification. Two new oscillator types, primarily intended for low power timekeeping, have been added. Numerous modifications and additions have been made to requirements specifying performance, test, design and construction, and quality and reliability assurance. Definitions have been expanded. This paper describes some of the more significant changes which are of greatest interest to the PTTI community.

NEW DEVICE TYPES

Device types covered by MIL-0-55310B are shown in Table 1. The two new device types are the microcomputer compensated crystal oscillator (MCXO)^[1] and the rubidium crystal oscillator (RbXO)^[2]. Precision crystal oscillators, i.e., crystal oscillators with aging better than 5×10^{-10} /day, short-term stability better than 1×10^{-11} (@ 1 sec), and overall accuracy better than 1×10^{-8} /year due to all factors, include the RbXO and high-performance OCXO and OCVCXO. MCXO are capable of aging rates comparable to OCXO and overall accuracies of 5×10^{-8} /year. But the MCXO, intrinsically, has poor short-term stability. These performance characteristics, when considered collectively, currently exclude the MCXO from the high precision class. From this standpoint, the RbXO is the more significant of the two new device types, although under certain operating conditions both the MCXO and RbXO can provide precise time as defined by DoD Directive 5160.51, dated 14 June 1985.

The RBXO

The RbXO is an oven-controlled crystal oscillator combined with a rubidium reference source. It is intended to make precise time and frequency available to military systems that lack the power required for sustained operation of atomic frequency standards. A basic block diagram of the RbXO is shown in Figure 1.

In operation, the rubidium reference is turned on intermittently, for a period of about five minutes, to frequency adjust (syntonize) the voltage-controlled OCXO. The OCXO, designed for low power consumption, e.g., the tactical miniature crystal oscillator (TMXO)^[3], is on continuously. A digital tuning memory retains the frequency-control voltage until the next syntonization. Time between syntonizations is adjustable, depending on system accuracy requirements and operating conditions. This method provides near-rubidium standard accuracy at a total power consumption not much more than the OCXO itself.

The RbXO has introduced two new specification requirements. One is "syntonization energy," which establishes the RbXO's low power capability. Figure 2 shows a typical rubidium reference supply current versus time characteristic for a RbXO during the syntonization period at a temperature of -55°C . Inspection consists in determining the syntonization energy from the time integral of rubidium reference supply power that is approximated using the trapezoidal rule for n equally spaced intervals. Prior to the test, the energized crystal oscillator portion of the RbXO is fully stabilized and the rubidium reference is temperature stabilized in the OFF state. Following turn-on of the rubidium reference, termination of the syntonization period is automatic. The other new requirement is "magnetic susceptibility," which specifies RbXO output frequency as a function of a dc magnetic field. The test requires measurement of the frequency change caused by a reversal of a specified dc magnetic field (provided by a Helmholtz coil pair).

FREQUENCY-TEMPERATURE PERFORMANCE AND TEST

Initial Frequency-Temperature Accuracy

A major defect in Revision A was a lack of standardization in specifying frequency-temperature performance. It was found that, among the oscillator manufacturers and users, "frequency-temperature stability" took on different meanings. As illustrated in Figure 3, some interpreted it as frequency-temperature deviation limits, (f_{max} and f_{min} , referenced to nominal frequency), some referenced the deviation limits to frequency measured at standard room ambient (T_{ref}), while still others used no reference, (i.e., they considered only relative peak-to-peak deviation). Each interpretation can provide different apparent performance and lead to confusion and conflict between user and manufacturer. This lack of standardization exists throughout the industry today, and is evident in published

product specification sheets.

The solution was to establish "initial frequency-temperature accuracy" as the preferred method for specifying frequency-temperature performance. It is defined as the "initial maximum permissible deviation of the oscillator frequency from the assigned nominal value due to operation over the specified temperature range," at nominal supply voltage and load conditions, other conditions remaining constant. For inspection, initial frequency-temperature (f-T) accuracy is determined by:

$$f - T \text{ accuracy} = \pm \text{MAX}[\delta f_{\text{max}}, \delta f_{\text{min}}]$$

where MAX [] is the maximum value of the fractional frequency deviations, and δf_{max} and δf_{min} are computed as

$$\delta f_{\text{max}} = |(f_{\text{max}} - f_{\text{nom}})/f_{\text{nom}}|$$

$$\delta f_{\text{min}} = |(f_{\text{min}} - f_{\text{nom}})/f_{\text{nom}}|$$

For non-frequency-adjustable (manufacturer-calibrated) oscillators, the initial frequency-temperature accuracy applies at the time of manufacture and for a specified period following shipment. For frequency-adjustable (manufacturer-/user-calibrated) oscillators, the initial frequency-temperature accuracy applies at the time immediately following calibration by the manufacturer or user.

"Frequency-temperature stability," is retained in Revision B as a special requirement for use in cases where a relative frequency-temperature change is required to be specified. It is now explicitly defined, with no reference implied, as:

$$f - T \text{ Stability} = \pm(f_{\text{max}} - f_{\text{min}})/(f_{\text{max}} + f_{\text{min}}).$$

FREQUENCY AGING

Initial aging

Initial frequency aging is a critical requirement for many precision OCXO applications. Military equipment frequently requires stable performance for short-duration missions. Commencing with oscillator warmup, rapid frequency excursions, such as shown in Figure 4, may occur within 48 hours after thermal stabilization. This effect is believed to be due to contamination transfer inside the resonator enclosure, stress relief, or thermistor drift. It generally tends to be more pronounced after cold temperature storage. As a standard condition, Revision B specifies storage at -40°C for 24 hours preceding turn-on, and specifies that data be taken for 48 hours. The first data point is taken at the specified warm-up time, 10 minutes in this example. Since the frequency change may be nonmonotonic, a maximum allowable frequency change over the test duration is specified. A maximum rate of frequency change can be specified if the application requires it. The test may be performed as an extension of the frequency warm-up test, provided that the storage conditions are met.

Long-Term Aging

Specification of long-term frequency aging for precision crystal oscillators is based upon a method previously described for precision quartz crystal units^[4]. Performance is now required to be specified by at least two parameters, i.e., total frequency change over a 30-day test period and projected frequency change for one year. A maximum aging rate per day at day 30 can also be specified. One can also specify total change for extended periods of time, e.g., 5 or 10 years. In spite of the well known uncertainty concerning

the extrapolation of aging data, it was decided that an imperfect means of specifying aging for extended periods was preferable to not specifying such performance at all. The method of extrapolation may need to be refined in the future (via an amendment to the specification, for example). System designers should be aware of the risks associated with the extrapolation.

Inspection for long-term aging consists of measuring frequency over a 30-day period and performing a least-squares fit of the data to the function:

$$f(t) = A(\ln(Bt + 1)) + f_o,$$

where $f(t)$ is the frequency of the crystal oscillator, t days after the start of the aging cycle, and A , B , and f_o are constants to be determined from the least-squares fit. If analysis of the data indicates that the aging trend is not monotonic, i.e., exhibits a reversal, an extension of the 30-day test period is required.

Figure 5 provides an example of aging inspection data for a TCXO at a specified measurement temperature of 60 °C. Similar inspection is applicable to precision OCXO, except that test is conducted at standard room ambient. Frequency measurements are required to be made a minimum of four times per week, for four weeks, following a two-day stabilization period. These are the points plotted. The solid line is a plot of the log equation extrapolated to one year, using the computed coefficients displayed in the upper left. Computed parameter values (upper right) are then compared to the specified values. The procedure requires that the rms of residuals of the data from the function be held to less than 5 percent of the specified total change. Five percent represents a limit within which a valid fit is assumed.

By definition of frequency aging, MIL-0-55310B inspection for long-term stability is performed under constant operating and environmental conditions. The term "drift," used on occasions to specify long-term stability, is ambiguous and subject to various interpretations. For example, drift has been used to describe frequency change resulting from a varying temperature or supply voltage over a period of time. It is the intent of Revision B to standardize in the use of "frequency aging," and to eliminate the promulgation of "drift" in the specification of long-term stability.

VIBRATION-INDUCED PHASE NOISE PERFORMANCE AND TEST

Acceleration sensitivity, vibration

Vibration-induced phase noise is becoming an increasingly critical requirement of precision crystal oscillators specified for use in tactical equipment. Because of the crystals' acceleration sensitivity^[5], a crystal oscillator operating under the dynamic conditions encountered in a tactical environment will have a phase noise considerably greater than it has under steady-state conditions. Although phase noise limits under application -specific vibration conditions can be specified in some instances, the preferred MIL-0-55310B parameter for general specification of vibration-induced phase noise performance and test is "acceleration sensitivity, vibration." Since this parameter is specified by a single maximum value and has vector properties, it conveniently characterizes the oscillator for either random or sinusoidal vibration conditions. Vibration-induced phase "noise," (f_y), due to sinusoidal vibration can then be calculated from the expression:

$$\mathcal{L}(f_y) = 20 \log \left[\frac{\bar{\Gamma} \cdot \vec{A} f_o}{2 f_y} \right],$$

where $\bar{\Gamma}$ is the acceleration sensitivity, A is the acceleration in g , f_y is the vibration frequency, and f_o is the crystal oscillator frequency. Similarly, random vibration-induced

phase noise, $\mathcal{L}(f)$, can be calculated from the same expression, except that, for the random vibration case, $|A| = (2 \times PSD)^{1/2}$, where PSD = the power spectral density of the vibration.

The prescribed test requires subjecting the crystal oscillator to sinusoidal vibration along each of three mutually perpendicular directions, i , j , and k , at a specified low (less than 20g) acceleration level, and measuring the single sideband phase noise (power ratio in dB) at no fewer than 7 frequencies per decade over the specified vibration frequency range. The acceleration sensitivity is computed at each vibration frequency, with the largest value among these representing the acceleration sensitivity for the i^{th} axis, i.e., Γ_i . The procedure is repeated for the j and k axes to compute Γ_j and Γ_k . The magnitude of the acceleration sensitivity vector is then obtained by taking the square root of the sum of squares, i.e.,

$$|\vec{\Gamma}| = \sqrt{\Gamma_i^2 + \Gamma_j^2 + \Gamma_k^2}$$

The direction of maximum or, conversely, minimum acceleration sensitivity may be specified. Also, if specified, the direction of the acceleration sensitivity vector, expressed in terms of its three unit vectors, can be supplied for each oscillator produced.

OTHER NEW PERFORMANCE REQUIREMENTS

The majority of new performance requirements included in Revision B fall in the category of special requirements, i.e., they are applicable when specifically required by the associated oscillator specification sheet. "Initial frequency aging" and "acceleration sensitivity, vibration" are included in this group. A partial listing of other new special requirements applicable to precision crystal oscillators is as follows:

- Allan variance
- Phase noise, acoustic
- Frequency warm-up
- Retrace
- Radiation hardness
- Built in test (BIT)

Inspection methods for each of the new performance requirements have also been included.

DESIGN AND CONSTRUCTION

Design and construction requirement changes now require specification of the construction technology to be employed for each oscillator device. Three categories of construction technology are included, i.e., discrete, custom hybrid microcircuit, and mixed. Special criteria are applied to each category. Packaged devices used in discrete construction are required to comply with requirements for either established reliability or JANTX parts; custom hybrid microcircuit construction is required to be in accordance with applicable requirements of Appendix G, MIL-M-38510^[6]. Mixed construction, which combines discrete and hybrid microcircuit assemblies, requires that the hybrid portion be screened in accordance with MIL-STD-883^[7].

QUALITY/RELIABILITY ASSURANCE

Two product assurance levels, Class B and Class S, have been established. Oscillators are now required to be 100 percent screened at stress levels appropriate to the device class and the construction technology used.

Within 24 months from issuance of Revision B, manufacturers of hybrid microcircuit oscillators will be required to show compliance with MIL-STD-1772.8 That document currently

imposes a uniform set of standards for line certification and process quality on manufacturers of general military hybrid microcircuits covered by MIL-M-38510. It is intended that hybrid crystal oscillator manufacturers provide at least comparable quality and reliability assurance.

CONCLUSION

Revision B has resulted in changes to MIL-0-55310, which will permit specification and acquisition of precision quartz crystal oscillators for the majority of evolving applications. Definitions, performance descriptions, and inspection methods introduced by the document are intended for standardization within the frequency control and timekeeping communities. Because of the newness of several performance requirements and test methods, some fine-tuning will inevitably be required as the specification matures. Minor changes will be incorporated by amendment as the need arises.

Currently there is no general military specification for atomic frequency standards. A need exists for a military-industry coordinated specification that would permit acquisition of atomic frequency standards manufactured with uniform test methods, procedures and criteria, and consistent levels of quality and reliability. Inasmuch as most technical requirements are common among precision quartz crystal oscillators and atomic standards, it is proposed that a future MIL-0-55310 revision incorporate atomic frequency sources.

Also highly desirable is a guide to the specification of oscillators. Since oscillators are often specified by system designers who do not have a sufficient understanding of oscillator behavior, such a guide is needed in order to minimize the occurrence of serious problems that result from poorly prepared specifications.

MIL-0-55310B will be published (i.e., will be in effect) in 1988. Copies will then be available from:

Naval Publication and Form Center
5801 Tabor Ave.
Philadelphia, PA 19120

ACKNOWLEDGEMENTS

The authors thank Dr. Raymond L. Filler and Mr. Vincent Rosati, of LABCOM, who contributed substantially to upgrading the specification. A special thanks to all those in government and industry who participated in the coordination of this revision for their valuable comments and helpful discussions.

REFERENCES

1. M. Meirs, "Lateral Field Resonator Development - Phase II," Frequency Electronics, Inc., Mitchel Field, NY and US Army LABCOM, Fort Monmouth, NJ, Research and Development Technical Report No. SLCET-TR-85-0403-1, July 1987.
2. J. R. Vig and V. Rosati, "The Rubidium Crystal Oscillator Hybrid Development Program," Proc. 16th PTTI Applications and Planning Meeting, pp. 157-165, 1984.
3. D. Brown, E. Laszlo, R. McGill, and P. Stoermer, "Manufacturing Methods and Technology for Tactical Miniature Crystal Oscillator," Proc. 38th AFCS, pp. 380-386, 1984.

4. R. L. Filler, "Aging Specification Measurement, and Analysis," Proc. 7th Quartz Crystal Conference, pp. 93-104, 1985.
5. R. L. Filler, "The Acceleration Sensitivity of Quartz Crystal Oscillators: A Review," Proc. 41st AFCS, pp. 398-408, 1987.
6. Military Specification: "Microcircuits, General Specification for, " MIL-M-38510F, 1983.
7. Military Standard: "Test Methods and Procedures for Microelectronics," MIL-STD-883C, 1983.
8. Military Standard: "Certification Requirements for Hybrid Microcircuit Facilities and Lines," MIL-STD-1772A, 1987.

Table 1

Oscillator Types

- XO - Crystal Oscillator
- VCXO - Voltage-Controlled Crystal Oscillator
- TCXO - Temperature-Compensated Crystal Oscillator
- OCXO - Oven-Controlled Crystal Oscillator
- TCVCXO - Temperature-Compensated/Voltage-Controlled Crystal Oscillator
- OCVCXO - Oven-Controlled/Voltage-Controlled Crystal Oscillator
- MCXO - Microcomputer-Compensated Crystal Oscillator
- RbXO - Rubidium-Crystal Oscillator

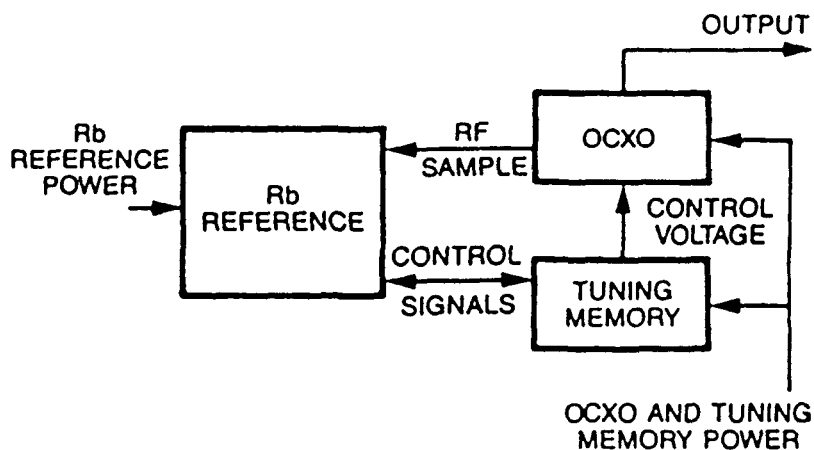

Figure 1. RbXO basic block diagram.

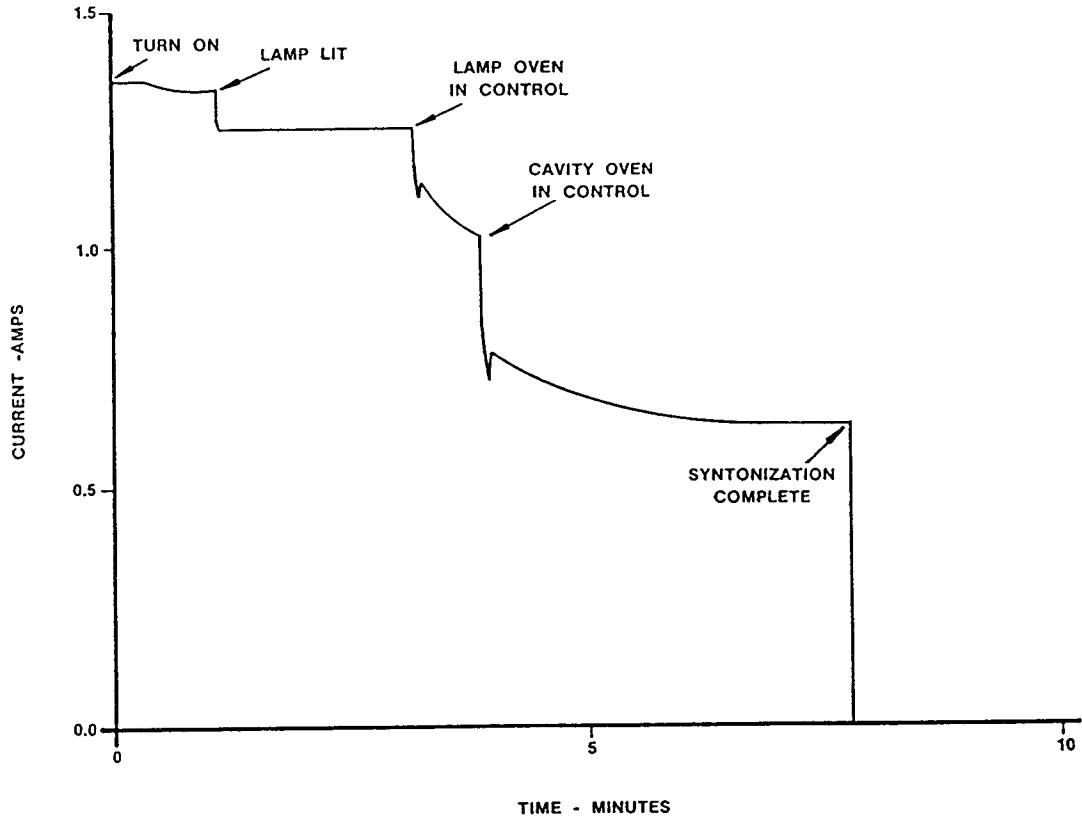

Figure 2. Typical RbXO syntonization current at -55°C .

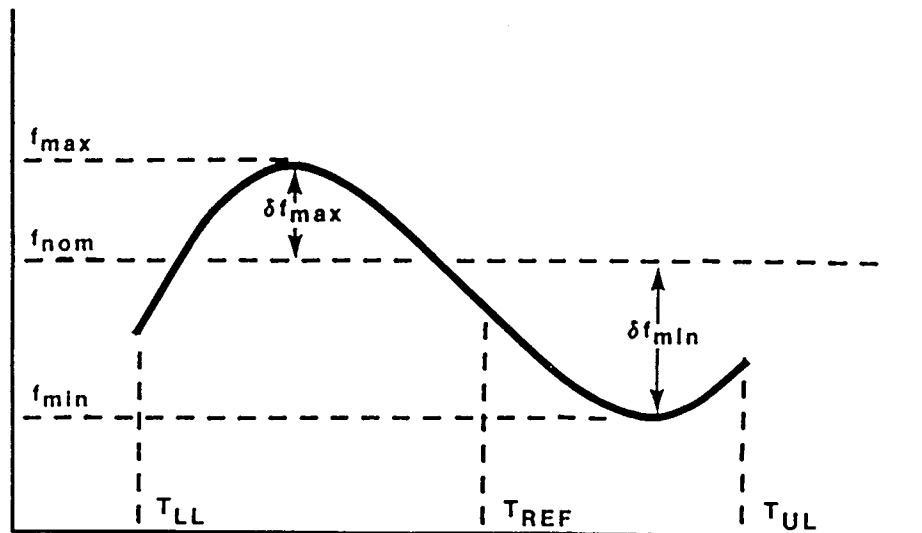

Figure 3. Representation of frequency-temperature performance. Over the temperature range ($T_{UL} - T_{LL}$), f_{max} and f_{min} have been arbitrarily referenced to either a.) f_{nom} , b.) frequency at T_{ref} or c.) relative to each other (no reference implied).

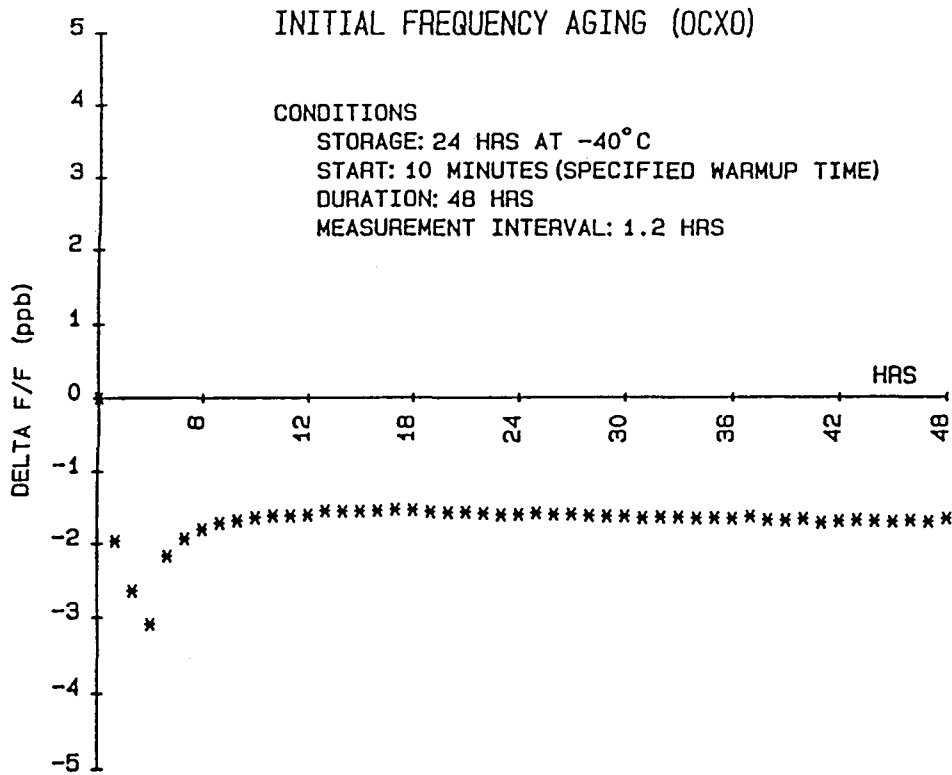

Figure 4. Initial frequency aging inspection for a 10 MHz OCXO.

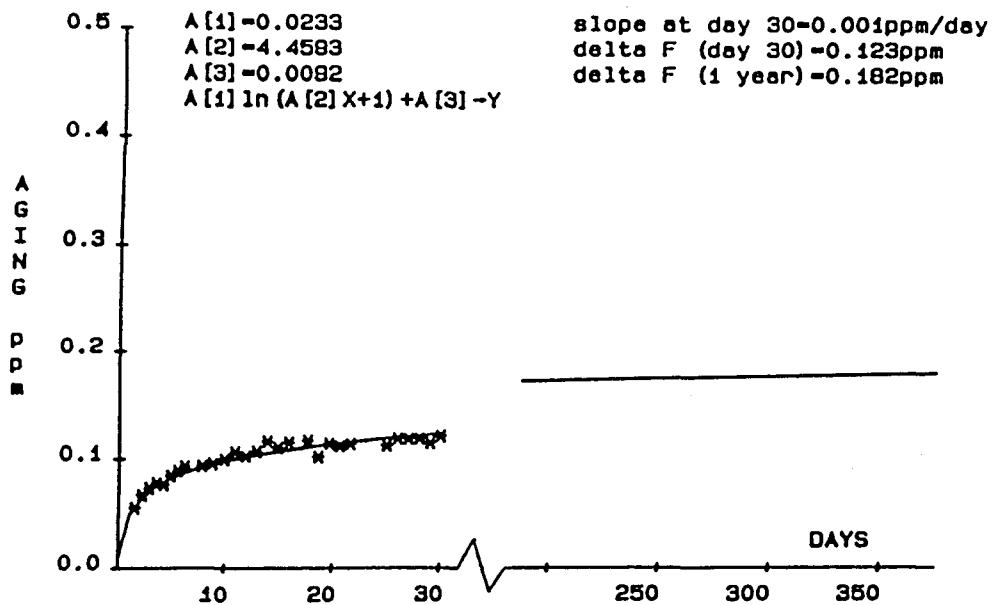

Figure 5. Long term frequency aging inspection data for a 3.2 MHz TCXO.

QUESTIONS AND ANSWERS

Bill Collings, Pan American: With regard to the RBXO, since the rubidium is not primary, did you prototype that and what experience did you have in turning the power on and off? When it came up every time, what was the reproducibility?

Dr. Vig: We gave a paper about three years ago about the RBXO and at that time we had turned the RBXO on and off 4000 times. We had no problems. There was no problem with reliability and the aging of the rubidium was the same as if it had been on continuously for that time. In other words, it was well behaved. Four thousand on-off cycles, done one per week, corresponds to a long-lived system. We feel comfortable that the RBXO is now a proven technology and we encourage people to use it whenever needed.

Paul Kuhnle, Jet Propulsion Laboratory: Have you covered in your specifications the problems of 60 Hz getting into the oscillator sidebands?

Dr. Vig: I believe that that is part of it, yes.

Mr. Kuhnle: We are seeing a lot of problems at the sideband levels that we have to deal with.

Dr. Vig: Of course, that also has to do with how it is installed in the equipment.

Mr. Kuhnle: We are seeing it both from the power supply voltage and from magnetic induction.

Dr. Vig: I am not too sure that 60 Hz is called out, but susceptibility to interference is called out.

Albert Kirk, Jet Propulsion Laboratory: On the Allan Variance specification, do you ask that the drift be removed?

Dr. Vig: Yes, that's right.